

General Packaging Standard

88P311

Revision J

June 2, 2011

Created By:

David Batz	Xerox Packaging Engineering Services
Chris Donnelly	Xerox Packaging Engineering Services
Mark James	Xerox Wilsonville Packaging Engineering
Dave Leinberger	Xerox Wilsonville Packaging Engineering
Paul McKenzie	Xerox European Packaging Group

This document is available on Xerox.com

http://www.xerox.com/downloads/usa/en/8/88P311_Rev_J.pdf

This document and the data contained herein, is the exclusive property of Xerox Corporation and/or Xerox Europe. Reproduction, transfer, disclosure or use for any purpose other than as required in the normal course of business is unauthorized unless approved by Xerox Corporation and/or Xerox Europe, Xerox Canada Ltd. and Xerox Latin America/Americas Operations

Revision	Date	Changes
G	May 2008	Major revision of content and format.
H	April 2010	Changed title to “General Packaging Standard” Revised Scope (Section 2) Added Stack height symbol calculation Added Pallet under-hang limit Clarified slipsheet and non-standard pallet use and approval Revised SPAF Section Updated pallet load height limit Added Section 6.13 – Secondary Packaging Guidelines Updated table of contents Added hyperlink to Xerox.com
J	June 2011	Modified max pallet load height section 6.6 Added min pallet opening dimension section 6.6 Added dimensions to pallet examples in section 6.6 Modified banding, stretch wrap and load overhang in section 6.8 Added no floor load requirement to section 6.10 Updated trap door and label location requirement in section 9.2

TABLE OF CONTENTS		
SECTION		PAGE
1.0	Purpose	4
2.0	Scope	4
3.0	Package Categories	4
4.0	Reference Documents	4
5.0	Definitions	5
6.0	General Requirements	6
	6.1 Transportation	6
	6.2 Labeling	6
	6.3 Environmental	6
	6.4 Maximum Manually Handled Package Weight	6
	6.5 Internal Packaging	6
	6.6 Pallets	6
	Table 6.6.1 - Acceptable Sizes and Styles	7
	6.7 Slip Sheets	7
	6.8 Securing Freight	8
	6.9 Safe Stack Height	9
	6.10 Ocean Container Utilization	9
	6.11 Single Parcel Delivery	9
6.12 Secondary Packaging Guidelines	9	
6.13 Electrostatic Discharge (ESD)	10	
7.0	Supplier Packaging Agreement Form (SPAF)	10
8.0	Field Replacement Unit /Spares Packaging	11
9.0	Machine Package Design	12
10.0	MN Containers	14
A	Appendix A – Label location on MN containers	18

1.0 PURPOSE

This standard sets out the packaging and distribution requirements for delivery of all materials to any Xerox Corporation, Xerox Limited, or affiliate location.

2.0 SCOPE

This document is applicable to all packaged categories (section 3.0) delivered to any Xerox manufacturing, distribution facility or end customer, whether from an external supplier or Xerox.

3.0 PACKAGE CATEGORIES

Five package categories are used in this specification. Each category is based on the item or items contained in the package.

Machines: A product that performs a function on its own without the need of additional items. Examples include but not limited to printer or image output terminal (IOT), scanner or image input terminal (IIT) and multifunction product (MFP).

Options: Items that are added to machines to provide additional capabilities. Examples include but not limited to second feeder, finisher, high capacity feeder and cart.

Consumables / Supplies: Item consumed by product during normal operation. Examples include but not limited to toner, ink, paper, drum cartridge, print cartridge, fuser, and developer and photoreceptor.

Field Replacement Unit (FRU) / Spares: Any part or assembly made available to support unscheduled replacement of like parts in existing equipment.

Incoming Materials to Xerox Manufacturing: Any material coming into a Xerox manufacturing facility that becomes assembled or made into a product.

4.0 REFERENCE DOCUMENTS

The following Xerox Standards should be applied to all Machines, Options, Consumables / Supplies, Field Replacement Unit (FRU) / Spares and Incoming Materials to Xerox Manufacturing facilities.

Copies can be downloaded externally from <http://www.xerox.com/about-xerox/suppliers/enus.html>

Copies can be downloaded internally from

<http://xww.internal.world.xerox.com/Insight/customindex/PackagingCompetencyCenter.cfm?SID=104>

Standard	Name
MN2-810.13	Product and Package Testing Requirements for Transportation, Storage and Delivery
EHS-710	Environmental Health & Safety Requirements for Packaging
MN2-155.2	MN Product / Spares / Supplies & Consumables / Parts & Components Package Label Design Requirements
74P298	Pallet Material and Construction Specifications
88P313	Manufacturing Policy Requirements for Electrostatic Discharge (ESD) Control

5.0 DEFINITIONS

- **Consumable:** Also called Supply. Item consumed by product during normal operation. Examples include but not limited to toner, ink, paper, drum cartridge, print cartridge, fuser, and developer and photoreceptor.
- **Customer Replaceable Unit:** Customer installable item that requires scheduled replacement. This is considered a consumable.
- **Field Replacement Unit (FRU):** Any assembly made available to support unscheduled replacement of like parts in existing equipment.
- **Incoming Materials to Manufacturing:** Any material coming into a Xerox manufacturing facility that becomes assembled or made into a product.
- **Internal Tie:** Also called packaging insert. Item placed inside a machine to prevent damage during transportation. These items are removed before machine operation. Examples include ties, transit locks, foam blocks, etc.
- **Machine:** A product that performs a function on its own without the need of additional items. Examples include but not limited to printer or image output terminal (IOT), scanner or image input terminal (IIT) and multifunction product (MFP).
- **Option:** Items that are added to machines to provide additional capabilities. Examples include but not limited to second feeder, finisher, high capacity feeder and cart.
- **Packaging:** Any item that is used to protect, contain and/or transport a product, part or material. Packaging may be described as being primary, secondary or tertiary. Items that support the contents throughout their functional lifetime and remain as part of the printer are not packaging (e.g. toner cartridges).
- **Packaging Insert:** Also called internal tie. Item placed inside a machine to prevent damage during transportation. These items are removed before machine operation. Examples include ties, transit locks, foam blocks, etc.
- **Primary Packaging:** The first wrap or containment of a product. Contains the product or material (e.g. a box holding transparencies, a carton containing toner cartridge).
- **Secondary Packaging:** Packaging that contains the primary package (e.g. a carton containing boxes of transparencies).
- **Spare:** Any part made available to resolve unscheduled replacement of like parts in existing equipment.
- **Supply:** Also called consumable. Item consumed by product during normal operation. Examples include but not limited to toner, ink, paper, drum cartridge, print cartridge, fuser, developer and photoreceptor.
- **Tertiary Packaging:** Contains or holds primary and/or secondary packages primarily for transport purposes (e.g. shrink wrap, pallet).
- **Unitized Load:** The assembly of multiple packages into a combined load to be handled by machinery.

6.0 GENERAL REQUIREMENTS

NOTE: Any deviation from this standard must be approved by Xerox.

6.1 TRANSPORTATION TESTING

- Packages must comply with Xerox Standard MN2-810.13 - Product and Package Testing Requirements for Transportation, Storage and Delivery

6.2 LABELING

- Packages must comply with Xerox Standard MN2-155.2 - MN Product / Spares / Supplies & Consumables / Parts & Components Package Label Design Requirements.
- See Appendix 1 of this specification for label placement on MN containers.

6.3 ENVIRONMENTAL

- Packages must comply with Xerox Standard EHS-710 - Environmental Health & Safety Requirements for Packaging.

6.4 MAXIMUM MANUALLY HANDLED PACKAGE WEIGHT

- Secondary packages (including contents) for Consumable / Supplies, Field Replacement Unit (FRU) / Spares or incoming materials to Xerox manufacturing facilities must not exceed 15 kg (33 lbs). This is a Xerox ergonomics requirement to reduce injuries. Exceptions must be approved by Xerox.

6.5 INTERNAL PACKAGING

- Internal packaging materials shall not generate excessive dust or contaminants.
- No use of loose fill materials such as polystyrene peanuts or shredded paper is permitted.

6.6 PALLETS

- All pallets must comply with Xerox standard 74P298-Pallet Material and Construction Specifications.
- Minimum vertical opening for pallet entry must be 89mm (3.5 inches).
- Pallets for FRU/Spares, Consumables/Supplies and Incoming Materials to Xerox Manufacturing:
 - Pallet loads (product and pallet) must not exceed 1,200 x 1,000 x 1,257 mm (47.2 x 39.4 x 49.5 inches) outside dimensions, unless an exception reduces the overall cost. All exceptions must be approved by Xerox Package Engineering.
 - When shipping to Europe, a 1,200 x 1,000 mm (47.2 x 39.4 inches) open bottom, block style pallet is required unless an exception reduces the overall cost to Xerox or is required for safety reasons. All exceptions must be approved by Xerox Package Engineering. Xerox pallets 674K1250 and 74K1520 meet this requirement.
- Pallets for machines and options :
 - Pallet selection and size should minimize the overall cost to Xerox. The height of a loaded pallet must not exceed 2500 mm [98.4 in] unless pre-approved by Xerox Package Engineering.
 - Pallets listed in Table 6.6.1 are required for unitized loads of product unless an exception reduces the overall cost to Xerox or is required for safety reasons. All exceptions must be approved by Xerox Package Engineering.

6.0 GENERAL REQUIREMENTS cont.

TABLE 6.6.1: ACCEPTABLE SIZES AND STYLES

Part Number	Description		
501K01515	Stringer style, Heavy duty,		1200 mm x 1000 mm x 127 mm
502P67485	Stringer style, Medium duty,		1200 mm x 1000 mm x 116 mm
502P67006	Stringer style, Light duty,		1200 mm x 1000 mm x 111 mm
674K01250	Block style, Light duty,		1200 mm x 1000 mm x 129 mm
74K1520	Block style, Heavy duty,		1200 mm x 1000 mm x 141 mm

Stringer Style

- 501K01515
- 502P67006
- 502P67485

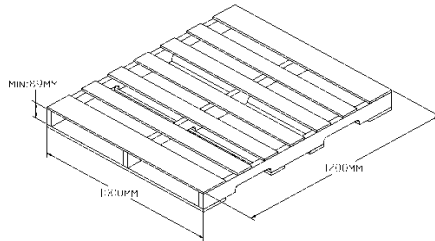

Block Style

- 674K1250
- 74K1520

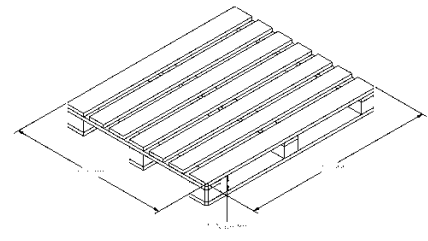

6.7 SLIPSHEETS

- Slip sheets can be used for Machines, Options and Consumables / Supplies if their use increases container utilization and reduces the overall cost to Xerox. Use of slip sheets must be pre-approved by Xerox Package Engineering. Slip sheets are not acceptable for FRU / Spares and Incoming Materials to Xerox Manufacturing.
- Slip sheets must have tabs on both the length and width.
- Slip sheets must have a locking corner.
- Footprint for slip sheet loads, not including tabs, must not exceed 1,200 x 1,000 mm (47.2 x 39.4 inches). Footprint of slip sheet, not including tabs, must not exceed load dimensions by more than 25 mm (1 inch).
- The height for slip sheet loads of Consumables / Supplies must not exceed 980 mm (38.6 inches). Any exceptions must be approved by Xerox Package Engineering. There is no height restriction for Machines or Options.

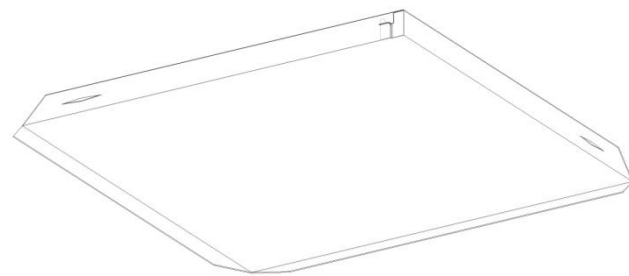
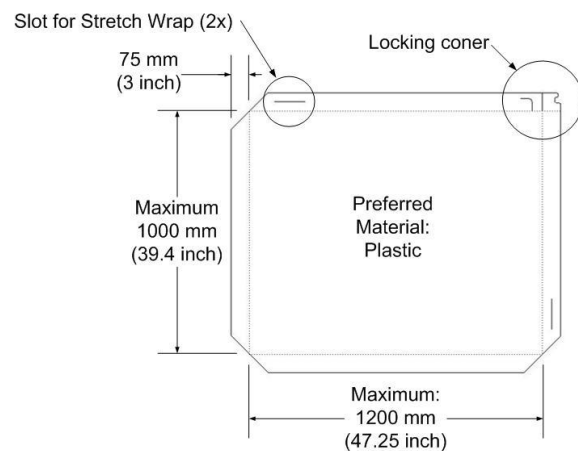

6.0 GENERAL REQUIREMENTS cont.**6.8 SECURING FREIGHT**

- **Stacking on Pallets and Slip Sheets:**

Load dimensions must not exceed the dimensions of the pallet or slipsheet. Loads must be secured to limit shifting during transit. Loads that shift more than 20 mm [0.8 inch] beyond the edge of the pallet during transit are unacceptable.

To facilitate safe pallet stacking, the pallet's bottom boards must maintain at least 38 mm [1.5 in.] contact area when top pallet is aligned with bottom load in any direction.

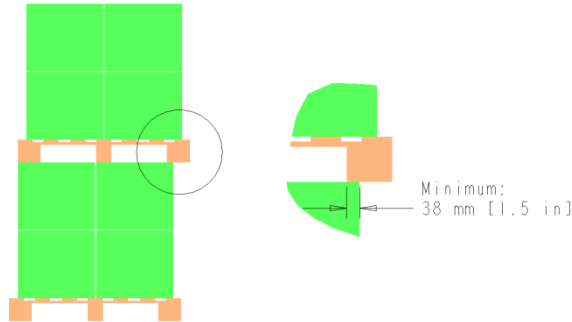

- **Securing Loads on Pallets and Slip Sheets:**

All cartons shall be secured to the pallet. Acceptable methods are plastic banding/strapping (for pallets) or plastic shrink/stretch film wrapping (for pallets and slip sheets).

Plastic banding/strapping (pallets):

Note: It is the Xerox safety policy not to accept metal banding. Exceptions for safety concerns or excessive weight must be formally authorized by Xerox Environmental Health Safety.

1. Plastic banding /strapping shall be of adequate strength and stability to prevent boxes from shifting beyond edge of pallet during use.
2. Edge protectors can be used to prevent banding/strapping from cutting boxes. Metal edge protectors are not permissible.
3. Banding / Strapping shall not obscure any bar code labels.
4. The Xerox Full Transport Label (Master Label or Mixed Load) for the unit load may be fixed to the banding with a wire tag.

Plastic Shrink/stretch film wrapping (pallets & slip sheets):

1. Shrink/stretch wrap shall extend low enough to adequately secure the load (boxes) to the pallet.
2. Stretch film must be of adequate tension to prevent boxes from shifting beyond edge of pallet.
3. Corner boards may also be used if required.
4. The Xerox Full Transport Label (Master Label or Mixed Load) for the unit load shall be fixed on the outside of the plastic film wrapping.

- **Securing loads within ocean container, truck or other vessel:**

Contents must be secured from movement during transport such that they are not damaged or create a safety hazard when unloading (e.g. block and brace).

6.0 GENERAL REQUIREMENTS cont.

6.9 SAFE STACK HEIGHT CALCULATION

Packages for machines, options, and consumables must include the ISO safe stacking symbol. Xerox calculates the safe stacking limit using the following formula:

$$5000/\text{Unit load height(mm) (rounded down)} \times \text{Layers of individual boxes in unit load} - 1$$

Safe stack symbol is not required on incoming materials to manufacturing, FRU/spares, and primary packages shipped within a secondary package (case package).

6.10 OCEAN CONTAINER UTILIZATION

- Packages must be placed on a pallet or slipsheet. Note that slipsheet usage must be pre-approved by Xerox. Loading packages directly on the floor is prohibited.
- Design pallet or slip-sheet loads and packages to maximize ocean container quantities. Minimum inside dimensions for common ocean containers are listed below.
- Allow at least 50 mm (2 inch) of total clearance in length, width and height to facilitate loading/unloading of the container.

Minimum Inside Dimensions	Length	Width	Height	Door Opening Height with dock plate
20 foot	5867 mm (231 inch)	2337 mm (92 inch)	2370 mm (93.3 inch)	2210 mm (87 inch)
40 foot Standard	11998 mm (472 inch)	2337 mm (92 inch)	2370 mm (93.3 inch)	2210 mm (87 inch)
40 foot high cube	11998 mm (472 inch)	2337 mm (92 inch)	2655 mm (104.5 inch)	2566 mm (99 inch)

6.11 SINGLE PARCEL DELIVERY

- To reduce freight charges, whenever possible, design packages that can be shipped via single parcel delivery (e.g. UPS, FedEx, etc.).
- Packages to be shipped via single parcel delivery must meet the following requirements:
 1. Package Weight \leq 68 kg (150 lb).
 2. Longest Package Dimension \leq 2,743 mm (108 in).
 3. Package Girth \leq 3,300 mm (130 in) where
Girth = (Largest dimension) + 2 x (next largest dimension) + 2 x (smallest dimension).
 4. Packages with girths up to 4,191 mm (165 in) are accepted into the single parcel delivery service, but are charged substantial additional fees.
 5. Additional fees charged for low density packages. To avoid these fees, packages must meet the following criteria:
 - Package weight (kg) must be \geq Length (cm) x width (cm) x height (cm) / 6000
 - Package weight (lbs) must be \geq Length (in) x width (in) x height (in) / 166
- Whenever possible, design packages that avoid the additional fees shown above.

6.0 GENERAL REQUIREMENTS cont.**6.12 SECONDARY PACKAGING GUIDELINES**

- Primary packages must be combined into a secondary (master) package if any of the following are true:
 1. Primary longest dimension is less than 229 mm [9 inch]
 2. The second longest dimension is less than 127 mm [5 inch]
 3. The smallest dimension is less than 51 mm [2 inch]
 4. Primary packages weighing less than 1.75kg [3.85 lbs]
- Secondary package quantity and dimensions should be selected to optimize a 1200 x 1000 mm Xerox standard pallet.
- Secondary package quantity should be no less than 8 or more than 20 unless pre-approved by Xerox packaging engineer
- Secondary package outside dimensions and weight must not exceed:
 - Length: 600 mm [23.625 inch]
 - Width: 500 mm [19.685 inch]
 - Height: 500 mm [19.685 inch]Secondary package must not exceed 15kg [33 lbs]

NOTE: If no configuration of 8 primary packages fall within the secondary package limits above, then no secondary package is required.

6.13 ELECTROSTATIC DISCHARGE (ESD)

Packages for static sensitive items must comply with Xerox Standard 88P313 - Manufacturing Policy Requirements for Electrostatic Discharge (ESD) Control

7.0 SPAF REQUIREMENTS

- A Supplier Packaging Agreement Form (SPAF) must be completed for all Incoming Materials to Xerox Manufacturing. A SPAF is not required for Machines, Options, FRU/Spares or Consumables/Supplies but must be used as a tool to document exceptions to 88P311.
- Supplier is responsible for submitting SPAF to Xerox. The form can be obtained at Xerox.com
<http://www.xerox.com/downloads/usa/en/5/51936-4.xls>
- The form must be submitted electronically through the Xerox DEX connectivity site. If you do not have access to DEX or need help with submitting the form please contact your Xerox representative.

8.0 FIELD REPLACEMENT UNITS (FRU) AND SPARES

- Primary, secondary and tertiary packages must comply with Section 6.0 of this standard.
- Secondary packages can **ONLY** contain one type of FRU / Spare (i.e. one part number).
- Tertiary packaging may contain more than one type of FRU / Spare (i.e. multiple part numbers). A mixed load shall be identified properly per MN2-155.2
- Primary and secondary package design and quantity must not change from one shipment to the next.
- For packaged FRU / Spares small enough to fit within a 152 x 152 x 102 mm (6 x 6 x 4 inch) volume, a shipping box is **not** required. Instead, several packaged FRU / Spares of the same part number can be placed into one larger secondary package and shipped to Xerox. The size of the secondary package can be chosen by the FRU / Spare supplier, but must not exceed 15 Kg (33 lbs). Refer to Table 8.1 for flow chart of this requirement.

TABLE 8.1 – DECISION FLOW CHART

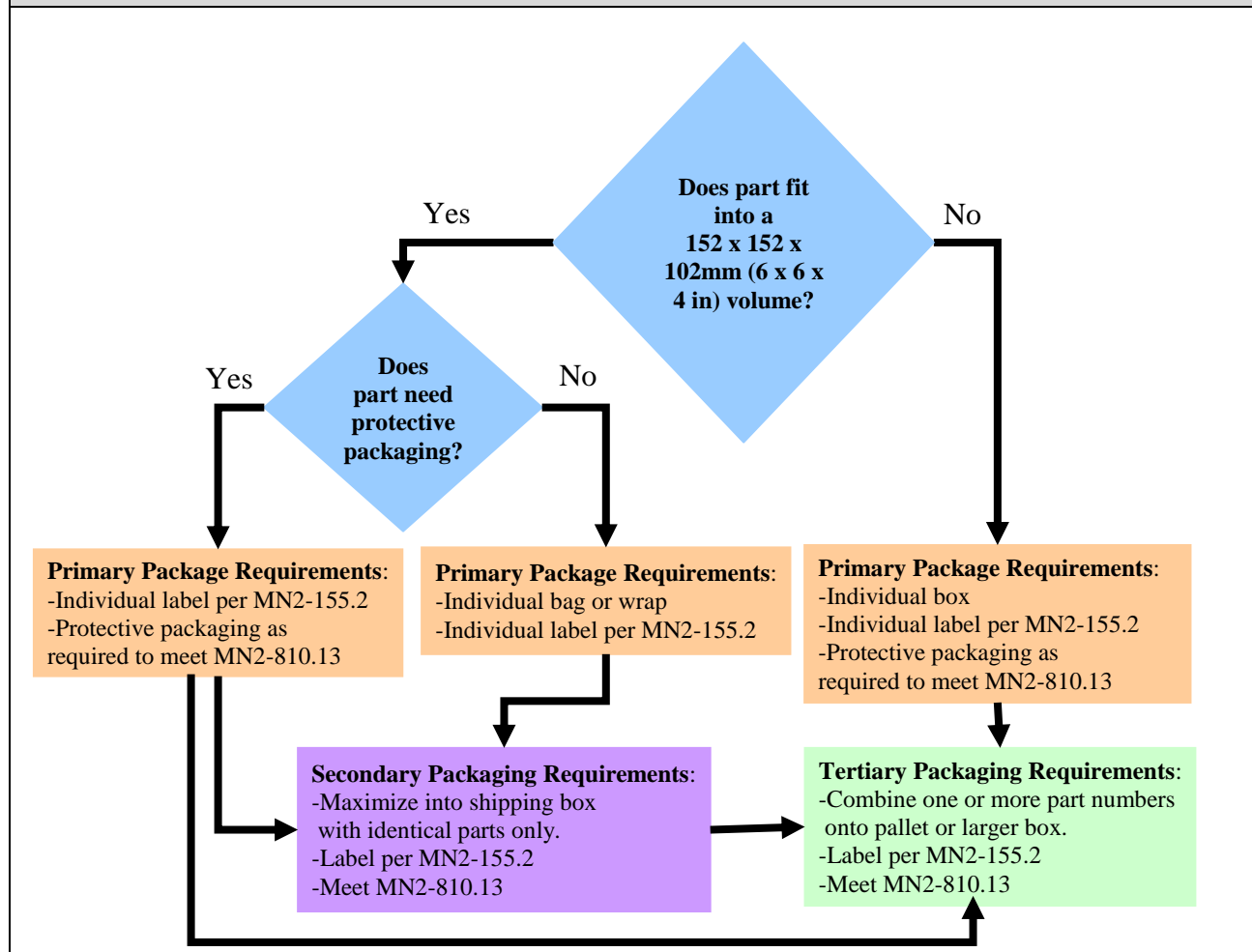

9.0 MACHINE AND PACKAGE DESIGN

9.1 PALLETS

- Pallets are required for packages over 45.5 kg (100 lbs).

9.2 IN-BOX CONFIGURATION/ POST HOLES

Some products are configured for their final destination using features designed into the packaging. The program team will define the in-box configuration requirements for each program. The configuration strategy details may be unique for each product, however there are three general approaches:

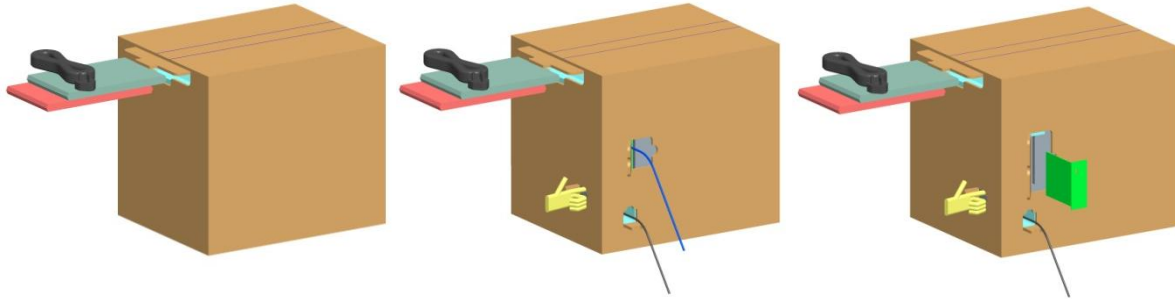

1. World/Nat kit and power cord:

Access to
World/ Nat kit
Power cord

2. Electronic Configuration

Access to
World/ Nat kit
Power cord
A/C plug
Power switch
Ethernet connector

3. Hardware Configuration

Access to
World/ Nat kit
Power cord
A/C plug
Power switch
Ethernet connector
Circuit Board

Note: Access doors must be easily opened without the need for tools. Access door and area must allow for installation and removal of World/Nat kit and power cord. Access to door and product label must be maintained while loaded on pallet. See detailed requirements in Xerox standard MN2-155.2

9.3 PACKAGING INSERTS

- The use of packaging parts inside the printer is strongly discouraged. If packaging inserts are required to pass MN2-810.13, they should meet all three of the following criteria:
 1. Insert must not damage product if left installed during power up.
 2. Insert must be easily re-installed by a customer.
 3. Xerox package engineering must pre-approve any insert or exceptions.

9.4 REVERSE LOGISTICS

- Packages should be designed for reverse logistics (e.g. customer and distributor returns).
- Best practices to facilitate reverse logistics include:
 1. Used product must pass transportation test without damage or leakage.
 2. No additional packaging inserts should be necessary to prevent damage. Any exception must be pre-approved by Xerox package engineering.
 3. Packaging should be designed to protect product without the addition of tape.

9.0 MACHINE AND PACKAGE DESIGN cont.

9.5 DESIGN FOR DELIVERY:

- The package design must support the delivery strategy for the intended markets. In some cases more than one delivery strategy is required. Xerox will define the delivery strategy for the product. Examples of our common delivery methods are included:

Pre-assembled

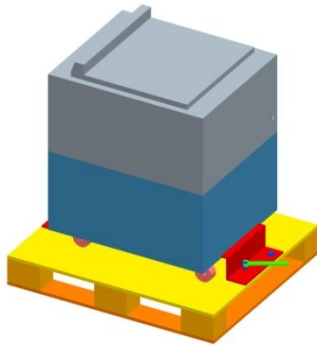

Rigger Install- Wrapped

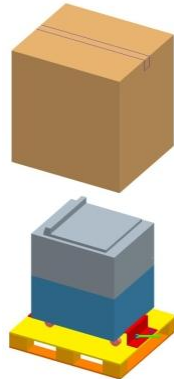

Rigger Install- Boxed



Customer Install

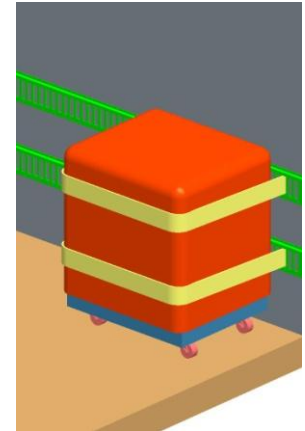

Un-palletized, Rigger Install

Unassembled



Over-boxed



Loosely Bundled

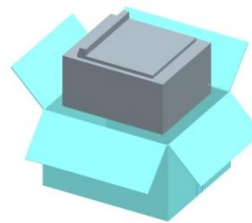

Separate Boxes

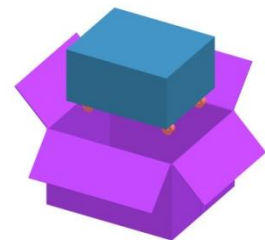

10.0 MN CONTAINERS

GENERAL REQUIRMENTS

- **MN Containers are used for incoming materials to manufacturing.**

- **Procurement and Testing MN Containers:**

Xerox has established worldwide sourcing for the multinational cartons. Suppliers will be permitted to purchase their cartons from these sources at prices pre-established with Xerox and the carton manufacturer. When purchasing MN cartons direct from the manufacturer, a minimum quantity purchase is required. If cartons are not obtained from the recommended Xerox source, performance data must be obtained and maintained to confirm that they meet the dimension and compression values in Tables 10.1, 10.2, 10.3 and 10.4. Suppliers will be required to provide data during SQA audits.

- **MN Container Drawings/Specifications:**

XEROX drawings may be obtained from the Xerox Document Center. External suppliers should contact their respective Xerox Buyer/Buyer Analyst to obtain copies of the Xerox engineering drawings. Questions on drawings should be addressed to the SQA representative, or to your local Packaging Engineering department.

- **MN Plastic Corrugated Containers:**

Xerox has made available a family of standard plastic returnable containers (Table 10.3). It is not proposed that these will replace paper corrugated cartons in all applications. These cartons are to be used whenever feasible. A detailed cost benefit analysis must be completed on a part by part basis to ensure that the use of a plastic returnable tote is financially justified and suits local customer requirements.

- **Maximum Permitted Weights:**

The total weight (including parts + internal packaging + containers) shall not exceed:

MN 1 in an MN 5 or 13	9 kg	(20 lb)
MN 1 through 5,10 through 13	15 kg	(33 lb)
MN 6	150 kg	(330 lb)
MN 7	300 kg	(660 lb)
MN 7.5	450 kg	(990 lb)
MN 8	600 kg	(1,323 lb)
MN 5 or 13 containing MN 1's	108 kg	(238 lb)

NOTE: When the MN 5 or 13 is used as an over shipper for MN 1's and its weight exceeds 15 kg (33 lb), it shall be clearly marked 'OVERWEIGHT' in letters at least 25 mm (1 in) high. The maximum allowable gross (total) weight shall be 600 kilograms (1,323 lbs.). Gross weight includes the pallet.

- **Label Placement on MN Containers:**

See Appendix A

- **Securing Cartons:**

All individual cartons that are shipped separately shall have their tops secured to their bases with plastic banding or tape.

The new MN2, MN3, MN4, and MN5 boxes are “one way” cartons and need to be assembled and taped. Any clear/transparent packing tape that is at least 2 inches wide and will adhere to the corrugated will be acceptable for taping the cartons.

10.0 MN CONTAINERS cont.

• **Unit Loads:**

All shipments that have a minimum of one full layer of cartons shall be palletized. The top layer of palletized loads must be covered. The SPAF process must identify whether this is achieved through the use of a top corrugated pad or the appropriate container lids as specified in Table 10.1, 10.2 or 10.3. When practical, a unit load should be cubed off.

Containers shall be stacked one directly above another (“column” or “tower” stacking), and not overlapping (“brick” stacking).

• **Mixed Unit Loads:**

It is preferred that each unit load should contain only one part number, but more than one part number is permitted. When a pallet holds a mixed load, cartons containing the same part number should be consolidated within the unit load. A mixed load shall be identified properly per MN2-155.2.

TABLE 10.1: MULTIPLE USE CORRUGATED MN CONTAINER PART NUMBERS, DIMENSIONS AND QUANTITY PER PALLET

MN ASSY DRAWING	MN CARTON	PIECE PART NUMBERS	LENGTH mm (inch)	WIDTH mm (inch)	DEPTH mm (inch)	MAX NO. OF CARTONS PER PALLET
MN1 504K02022	MN1 COVER (ID)	504E03761	258 (10.2)	112 (4.4)	102 (4)	240 or 12 per MN5 ***
	MN1 BASE (OD)	504E03772	254 (10)	108 (4.3)	101 (4)	
	MN1 BASE (ID)**	504E03772	248 (9.7)	102 (4)	95 (3.7)	
MN2 504K02032	MN2 COVER (ID)	504E03782	475 (18.7)	281 (11.1)	117 (4.6)	64 ***
	MN2 BASE (OD) MN2	504E03791	471 (18.5)	277 (10.9)	117 (4.6)	
	BASE (ID)**	504E03791	254 (10)	271 (10.7)	114 (4.5)	
MN3 504K02042	MN2 COVER (ID)	504E03802	479 (18.9)	281 (11.1)	66 (2.6)	32
	MN2 BASE (OD)	504803811	475 (18.7)	277 (10.9)	235 (9.3)	
	MN2 BASE (ID)**	504E03811	433 (17)	263 (10.4)	230 (9.1)	
MN4 504K02052	MN4 COVER (ID)	504E03822	574 (22.6)	382 (15)	117 (4.6)	40
	MN4 BASE (OD)	504E03831	570 (22.4)	378 (14.9)	117 (4.6)	
	MN4 BASE (ID)**	504E03831	553 (21.8)	372 (14.6)	114 (4.5)	
MN5 504K02262	MN5 COVER (ID)	504E04052	586 (23.1)	380 (15)	66 (2.6)	20
	MN5 BASE (OD)	504E04061	582 (22.9)	376 (14.8)	235 (9.3)	
	MN5 BASE (ID)**	504E04061	540 (21.3)	362 (14.3)	230 (9.1)	
MN6 504K02272	MN6 COVER (ID)	504E04032	954 (37.6)	574 (22.6)	70 (2.8)	2
	MN6 BASE (OD)	504E04041	950 (37.4)	570 (22.4)	404 (15.9)	
	MN6 BASE (ID)**	504E04041	935 (36.8)	556 (21.9)	393 (15.5)	
MN7 504K02162	MN7/7.5/8 COVER (ID)	504E03852	1163 (45.8)	971 (38.2)	175 (6.9)	1
	MN7 SLEEVE (OD)	504E04022	1155 (45.5)	963 (37.9)	396 (15.6)	
	MN7 SLEEVE (ID)**	504E04022	1124 (44.3)	932 (36.7)	396 (15.6)	
		504E03871	1153 (45.4)	961 (37.8)	N/A	
MN7.5 504K8340	MN7.5 SLEEVE (OD)	504E07860	1155 (45.5)	963 (37.9)	628 (24.7)	1
	MN7.5 SLEEVE (ID)**	504E07860	1124 (44.3)	932 (36.7)	625 (24.6)	
MN8 504K02062	MN8 SLEEVE (OD)	504E03842	1155 (45.5)	963 (37.9)	946 (37.2)	1
	MN8 SLEEVE (ID)**	504E03842	1124 (44.3)	942 (37.1)	946 (37.2)	

10.0 MN CONTAINERS cont.

TABLE 10.2: SINGLE USE CORRUGATED MN CONTAINER PART NUMBERS, DIMENSIONS AND QUANTITY PER PALLET

“ONE WAY” MN CARTON	PART NUMBERS	LENGTH mm (in)	WIDTH mm (in)	DEPTH mm (in)	MAX NO. OF CARTONS PER PALLET
MN 2 BASE	502P56251	454 (17.9)	270 (10.6)	114 (4.5)	64
MN 2/3 COVER	502P56252	465 (18.3)	283 (11.1)	114 (4.5)	***
MN 3 BASE	502P56253	454 (17.9)	270 (10.6)	230 (9.1)	32
MN 2/3 COVER	502P56252	465 (18.3)	283 (11.1)	114 (4.5)	
MN 4 BASE	502P56255	556 (21.9)	371 (14.6)	114 (4.5)	40
MN 4/5 COVER	502P56256	568 (22.4)	384 (15.1)	114 (4.5)	
MN 5 BASE	502P56257	556 (21.9)	371 (14.6)	230 (9.1)	20
MN 4/5 COVER	502P56256	568 (22.4)	384 (15.1)	114 (4.5)	

TABLE 10.3: MULTIPLE USE PLASTIC MN CONTAINER PART NUMBERS, DIMENSIONS AND QUANTITY PER PALLET

MN ASSY DRAWING	MN CARTON	PIECE PART NUMBERS	LENGTH mm (in)	WIDTH mm (in)	DEPTH mm (in)	MAX NO. OF CARTONS PER PALLET
MN10 504K08260	MN2 COVER (ID)	504E13760	494 (19.4)	283 (11.1)	50 (2)	64
	MN2 BASE (OD)	504E13720	488 (19.2)	281 (11.1)	119 (4.7)	***
	MN2 BASE (ID)**	504E13720	456 (18)	271 (10.7)	114 (4.5)	
MN11 504K08270	MN3 COVER (ID)	504E13760	494 (19.4)	283 (11.1)	50 (2)	32
	MN3 BASE (OD)	504E13730	488 (19.2)	276 (10.9)	235 (9.3)	
	MN3 BASE (ID)**	504E13730	456 (18)	266 (10.5)	230 (9.1)	
MN12 504K08280	MN4 COVER (ID)	504E13770	594 (23.4)	383 (11.1)	50 (2)	40
	MN4 BASE (OD)	504E13740	588 (23.1)	382 (11.1)	119 (4.7)	
	MN4 BASE (ID)**	504E13740	556 (21.9)	372 (14.6)	114 (4.5)	
MN13 504K08290	MN5 COVER (ID)	504E13770	594 (23.4)	383 (11.1)	50 (2)	20
	MN5 BASE (OD)	504E13750	588 (23.1)	374 (14.7)	235 (9.3)	
	MN5 BASE (ID)**	504E13750	556 (21.9)	364 (14.3)	230 (9.1)	

NOTES FOR TABLES 10.1, 10.2 AND 10.3:

- ID = Internal Dimension, OD = External Dimension. Cover ID = Minimum Value, Base ID = Minimum Value, Base OD = Maximum Value.
- All dimensions are inside nominal. For further information please refer to actual drawing specification.
- ** Dimension to be not less than specified.
- *** When weight limited, the maximum number of cartons per pallet will be the number of cartons per layer X the number of layers, not to exceed 600Kg weight limit (See Table 6.6.1).

10.0 MN CONTAINERS cont.

TABLE 10.4: COMPRESSION VALUES FOR MN CONTAINERS

- Compression test per MN2-810.13
- The design specifications for Xerox MN cartons are based on being capable of stacking 5 meters high. Either the weight in each carton or the board strength can be changed in order to meet the compression test requirements. It is up to the supplier to ensure that the cartons that they are purchasing are sufficient for the weights that they are shipping in each carton.

CORRUGATED		PLASTIC	
MN BOX	kg (lb)	MN BOX	kg (lb)
MN1	330 (728)	MN10	578 (1,274)
MN2	475 (1,047)	MN11	279 (615)
MN3	330 (728)	MN12	578 (1,274)
MN4	475 (1,047)	MN13	279 (615)
MN5	330 (728)		
MN6	700 (1,543)		
MN7	2,700 (5,952)		
MN7.5	2,700 (5,952)		
MN8	1,800 (3,968)		

APPENDIX A

APPENDIX 1. LABEL PLACEMENT FOR MN CONTAINERS

Recommended Label Format (MN1)

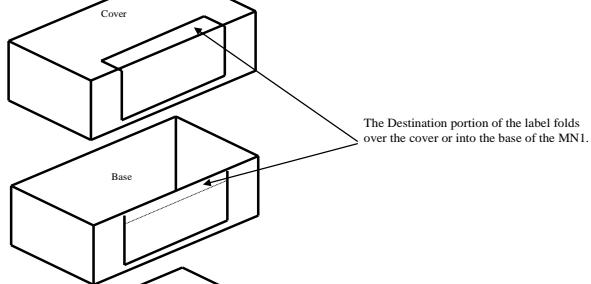

Alternate Label Format (MN1)

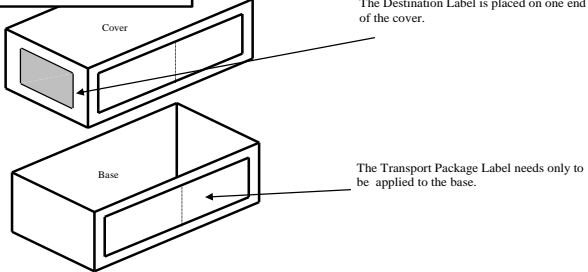

Recommended Label Format (MN2 & 10)

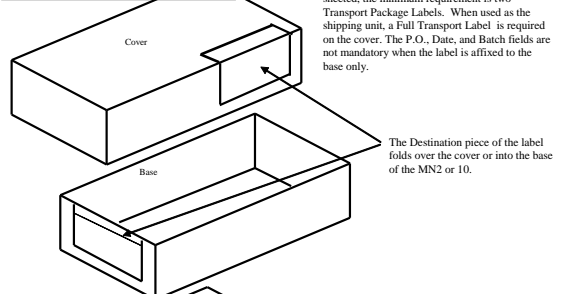

Alternate Label Format (MN2 & 10)

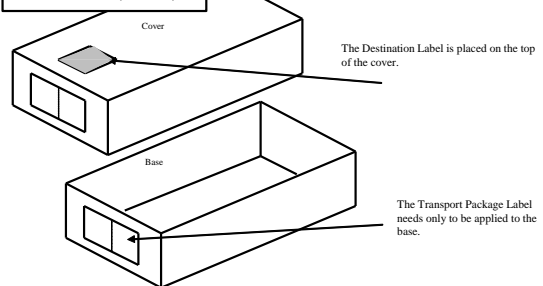

Note: When the box is to be palletized or slip sheeted, the minimum requirement is two Transport Package Labels. When used as the shipping unit, a Full Transport Label is required on the cover. The P.O., Date, and Batch fields are not mandatory when the label is affixed to the base only.

Recommended Label Format (MN3 & 11)

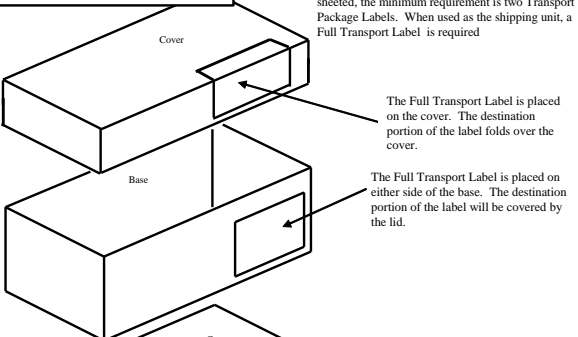

Alternate Label Format (MN3 & 11)

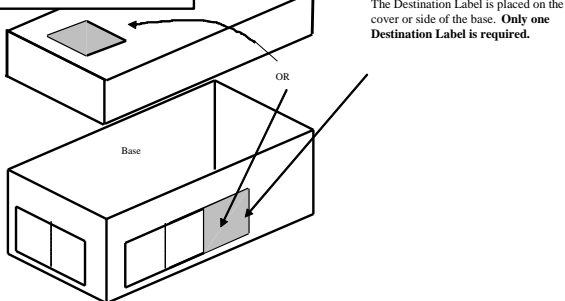

Recommended Label Format (MN5, 6 & 13)

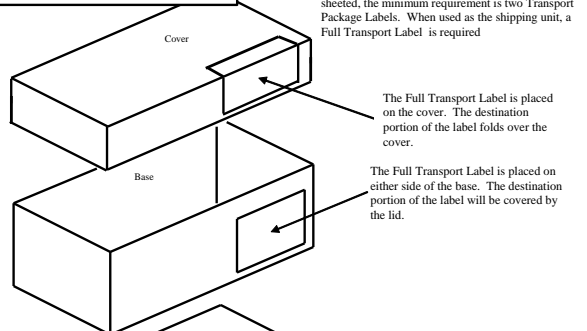

Alternate Label Format (MN5, 6 & 13)

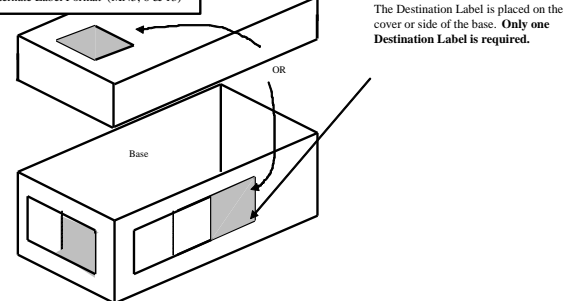

APPENDIX A

APPENDIX 1. LABEL PLACEMENT FOR MN CONTAINERS (CON'T)

Recommended Label Format (MN 7, 7.5, & 8)

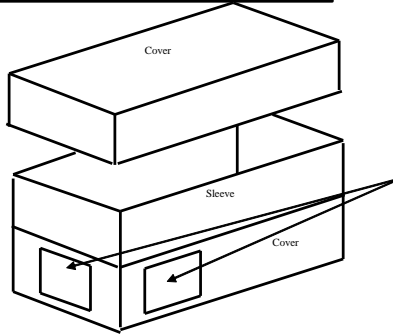

The Full Transport Label is placed on adjacent sides of the base cover.

Alternate Label Format (MN 7, 7.5, & 8)

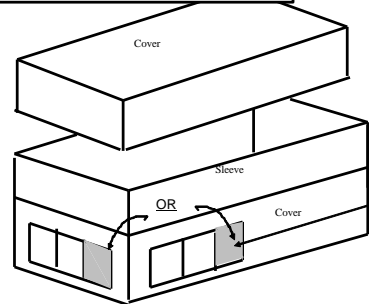

The Destination Label is placed beside the Transport Package Label. Only one Destination Label is required.

Figure 13. Label Locations on MN7, MN 7.5, & MN 8 Cartons